

Human-/Environmental-friendly, High-performance, General-purpose Inverters, Enabling Output Control Suitable for Various Applications

- With the vector control and auto-tuning functions, the RX Series has achieved high starting torque in excess of 200% at 0.3 Hz
- The RX Series provides sensorless vector control, which is useful for up/down applications
- Automatic energy-saving operation function. Automatically adjusts so that the Inverter output voltage during operation becomes minimum at a constant speed
- Checks the direction of rotation and frequency, enabling smooth restart of the motor for a free-running motor (e.g. fan motor)
- During a power failure or momentary power interruption, the RX Series can decelerate and stop a motor by using the motor braking energy
- More simplified parameter settings and views
Only parameters that have been changed from the default settings can be viewed
With the user setting function, only 12 parameters for frequent use can be viewed
- The RX Series incorporates a zero-phase reactor (radio noise filter) as a standard specification
- ModBus-RTU communication allows you to perform network operation at low cost

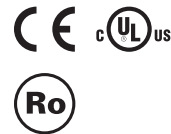

Model Number Explanation

3G3RX - A □ □ □ □

RX-series
Inverter

Maximum Motor Capacity

055	5.5 kW	220	22 kW
075	7.5 kW	300	30 kW
110	11 kW	370	37 kW
150	15 kW	450	45 kW
185	18.5 kW	550	55 kW

Voltage Class

2	3-phase 200 V AC
4	3-phase 400 V AC

Standard Models

Rated voltage	Enclosure rating	Max. applicable motor capacity	Model
3-phase 200 V AC	IP20	5.5 kW	3G3RX-A2055
		7.5 kW	3G3RX-A2075
		11 kW	3G3RX-A2110
		15 kW	3G3RX-A2150
		18.5 kW	3G3RX-A2185
		22 kW	3G3RX-A2220
		30 kW	3G3RX-A2300
		37 kW	3G3RX-A2370
45 kW		3G3RX-A2450	
55 kW		3G3RX-A2550	
3-phase 400 V AC		5.5 kW	3G3RX-A4055
		7.5 kW	3G3RX-A4075
		11 kW	3G3RX-A4110
		15 kW	3G3RX-A4150
		18.5 kW	3G3RX-A4185
		22 kW	3G3RX-A4220
	30 kW	3G3RX-A4300	
	37 kW	3G3RX-A4370	
45 kW	3G3RX-A4450		
55 kW	3G3RX-A4550		

International Standards (EC Directives and UL/cUL Standards)

The 3G3RX Inverter meets the EC Directives and UL/cUL standard requirements for worldwide use.

Classification		Applicable standard
ED Directives	EMC Directive	EN61800-3: 2004
	Low-voltage Directive	EN61800-5-1: 2003
UL/cUL Standards		UL508C

Standard Specification List

Three-phase 200-V Class

Class		3-phase 200 V										
Model name (3G3RX-)		A2055	A2075	A2110	A2150	A2185	A2220	A2300	A2370	A2450	A2550	
Max. applicable motor 4P	kW	5.5	7.5	11	15	18.5	22	30	37	45	55	
	Rated output capacity (kVA)	200 V	8.3	11.0	15.9	22.1	26.3	32.9	41.9	50.2	63.0	76.2
	240 V	9.9	13.3	19.1	26.6	31.5	39.4	50.2	60.2	75.6	91.4	
Rated input voltage		3-phase (3-wire) 200 V -15% to 240 V +10%, 50/60 Hz ±5%										
Rated output voltage		3-phase: 200 to 240 V (according to the input voltage)										
Rated output current (A)		24	32	46	64	76	95	121	145	182	220	
Weight (kg)		6	6	6	14	14	14	22	30	30	43	
Braking	Regenerative braking	Built-in braking resistor circuit (discharge resistor separately mounted)						Regenerative braking unit separately mounted				
	Minimum connection resistance (Ω)	17	17	17	7.5	7.5	5	-				

Three-phase 400-V Class

Class		3-phase 400 V										
Model name (3G3RX-)		A4055	A4075	A4110	A4150	A4185	A4220	A4300	A4370	A4450	A4550	
Max. applicable motor 4P	kW	5.5	7.5	11	15	18.5	22	30	37	45	55	
	Rated output capacity (kVA)	400 V	9.7	13.1	17.3	22.1	26.3	33.2	40.1	51.9	63.0	77.6
	480 V	11.6	15.8	20.7	26.6	31.5	39.9	48.2	62.3	75.6	93.1	
Rated input voltage		3-phase (3-wire) 380 V -15% to 480 V +10%, 50/60 Hz ±5%										
Rated output voltage		3-phase: 380 to 480 V (according to the input voltage)										
Rated output current (A)		14	19	25	32	38	48	58	75	91	112	
Weight (kg)		6	6	6	14	14	14	22	30	30	30	
Braking	Regenerative braking	Built-in braking resistor circuit (discharge resistor separately mounted)						Regenerative braking unit separately mounted				
	Minimum connection resistance (Ω)	70	35	35	24	24	20	-				

Common Specification

Item	Specifications
Enclosure rating	IP20
Cooling method	Forced air cooling
Control method	Phase-to-phase sinusoidal modulation PWM
Output frequency range	0.1 to 400Hz
Frequency precision	Digital command: ±0.01% of the max. frequency Analog command: ±0.2% of the max. frequency (25°C ±10°C)
Frequency resolution	Digital setting: 0.01 Hz Analog setting: Max. frequency/4000 (Terminal FV: 12 bits/0 to +10 V), (Terminal FE: 12 bits/-10 to +10 V), (Terminal FI: 12 bits/0 to +20 mA)
Voltage/Frequency characteristics	V/f optionally changeable at base frequencies of 30 to 400 Hz, V/f braking constant torque, reduction torque, sensorless vector control, sensor-less vector control at 0 Hz
Speed fluctuation	±0.5% (under sensor-less vector control or sensorless vector control at 0 Hz)
Overload current rating	150%/60 s, 200%/3 s
Acceleration/Deceleration time	0.01 to 3600.0 s (line/curve selection)
Starting torque	200%/0.3 Hz (under sensorless vector control or sensor-less vector control at 0 Hz) 150%/Torque at 0 Hz (under sensor-less vector control at 0 Hz, or when the motor with one frame fewer than the maximum applicable motor is connected)
DC injection braking	Operates when the starting frequency is lower than that in deceleration via the STOP command, when the frequency reference is lower than the operation frequency, or via an external input (braking power, time, and frequency settable)

Item		Specifications
Input	Multi-function input	8 terminals, NO/NC switchable, sink/source logic switchable [Terminal function] 8 functions can be selected from among 61. Reverse (RV), Multi-step speed 1 (CF1), Multi-step speed 2 (CF2), Multi-step speed 3 (CF3), Multi-step speed 4 (CF4), Jogging (JG), External DC injection braking (DB), 2nd control (SET), 2-step acceleration/deceleration (2CH), Free-run stop (FRS), External trip (EXT), USP function (USP), Commercial switch (CS), Soft lock (SFT), Analog input selection (AT), 3rd control (SET3), Reset (RS), 3-wire startup (STA), 3-wire stop (STP), 3-wire forward/reverse (F/R), PID disabled (PID), PID integral reset (PIDC), Control gain switching (CAS), UP/DWN function accelerated (UP), UP/DWN function decelerated (DWN), UP/DWN function data clear (UDC), Forced operator (OPE), Multi-step speed bit 1 (SF1), Multi-step speed bit 2 (SF2), Multi-step speed bit 3 (SF3), Multi-step speed bit 4 (SF4), Multi-step speed bit 5 (SF5), Multi-step speed bit 6 (SF6), Multi-step speed bit 7 (SF7), Overload limit switching (OLR), Torque limit enabled (TL), Torque limit switching 1 (TRQ1), Torque limit switching 2 (TRQ2), P/PI switching (PPI), Brake confirmation (BOK), Orientation (ORT), LAD cancel (LAC), Position deviation clear (PCLR), Pulse train position command input permission (STAT), Frequency addition function (ADD), Forced terminal (F-TM), Torque reference input permission (ATR), Integrated power clear (KHC), Servo ON (SON), Preliminary excitation (FOC), Position command selection 1 (CP1), Position command selection 2 (CP2), Position command selection 3 (CP3), Zero return limit signal (ORL), Zero return startup signal (ORG), Forward driving stop (FOT), Reverse driving stop (ROT), Speed/Position switching (SPD), Pulse counter (PCNT), Pulse counter clear (PCC), Analog command held (AHD), No allocation (no)
	Thermistor input terminal	1 terminal (Positive/Negative temperature coefficient of resistance element switchable)
Output	Multi-function output	5 open collector output terminals: NO/NC switchable, sink/source logic switchable 1 relay (SPDT contact) output terminal: NO/NC switchable [Terminal function] 6 functions can be selected from among 45. During operation (RUN), Constant speed reached (FA1), Set frequency exceeded (FA2), Overload warning (OL), Excessive PID deviation (OD), Alarm signal (AL), Set frequency only (FA3), Overtorque (OTQ), Signal during momentary power interruption (IP), Signal during undervoltage (UV), Torque limit (TRQ), RUN time over (RNT), Power ON time over (ONT), Thermal warning (THM), Brake release (BRK), Brake error (BER), Zero-speed signal (ZS), Excessive speed deviation (DSE), Position ready (POK), Set frequency exceeded 2 (FA4), Set frequency only 2 (FA5), Overload warning 2 (OL2), Analog FV disconnection detection (FVdc), Analog FI disconnection detection (FIDc), Analog FE disconnection detection (FEDc), PID FB status output (FBV), Network error (NDc), Logic operation output 1 (LOG1), Logic operation output 2 (LOG2), Logic operation output 3 (LOG3), Logic operation output 4 (LOG4), Logic operation output 5 (LOG5), Logic operation output 6 (LOG6), Capacitor life warning (WAC), Cooling fin overheat warning (WAF), Starting contact signal (FR), Cooling fin overheat warning (OHF), Low current signal (LOC), Operation ready (IRDY), During forward operation (FWR), During reverse operation (RVR), Fatal fault (MJA), Window comparator FV (WCFV), Window comparator FI (WCFI), Window comparator FE (WCFE), Alarm codes 0 to 3 (AC0 to AC3)
	Multi-function monitor output terminal	Analog voltage output, Analog current output, Pulse train output (A-F, D-F {multiplied by "n", pulse output only}, A, T, V, P, etc.)
Display monitor		Output frequency, Output current, Output torque, Frequency conversion value, Trip record, I/O terminal status, Electric power, etc.
Other functions		V/f free setting (7), Upper/lower frequency limit, Frequency jump, Curve acceleration/deceleration, Manual torque boost level/break, Energy-saving operation, Analog meter adjustment, Starting frequency, Carrier frequency adjustment, Electronic thermal function, (free setting available), External start/end (frequency/rate), Analog input selection, Trip retry, Restart during momentary power interruption, Various signal outputs, Reduced voltage startup, Overload limit, Initialization value setting, Automatic deceleration at power-off, AVR function, Fuzzy acceleration/deceleration, Auto tuning (Online/Offline), High-torque multi-operation control (sensor-less vector control of two monitors with one Inverter)
Carrier frequency modification range		0.5 to 15 kHz
Protective functions		Overcurrent protection, Overvoltage protection, Undervoltage protection, Electronic thermal protection, Temperature error protection, Momentary power interruption/Power interruption protection, Input open-phase protection, Braking resistor overload protection, Ground-fault overcurrent detection at power-on, USP error, External trip, Emergency shutoff trip, CT error, Communication error, Option error, etc.
Operating environment	Ambient/Storage temperature/Humidity	-10°C to 50°C/-20°C to 65°C/20% to 90% RH (with no condensation)
	Vibration *	3G3RX-A055/-A075/-A110/-A150/-A185/-A220: 5.9 m/s ² (0.6G), 10 to 55 Hz 3G3RX-A300/-A370/-A450/-A550: 2.94 m/s ² (0.3G), 10 to 55 Hz
	Location	At a maximum altitude of 1,000 m; indoors (without corrosive gases or dust)
Options	Feedback option	Sensor vector control
	Digital input option	4-digit BCD, 16-bit binary
Other options		Braking resistor, AC/DC reactor, Noise filter, Digital Operator cables, Regenerative braking unit, etc.

* Complies with the test method specified in JIS C0040 (1999).

Note: Insulation distance complies with UL/CE standards.

Terminal Block Specifications

Terminal Block Position

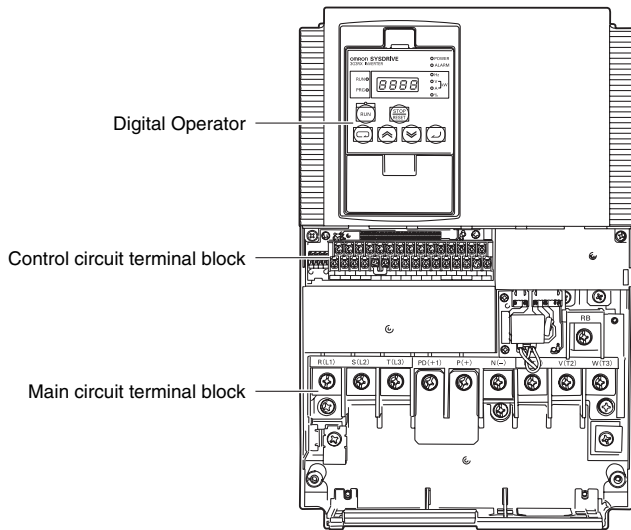

Note: This illustration shows the terminal block with the Terminal block front cover removed.

Arrangement of Main Circuit Terminals

Terminal arrangement

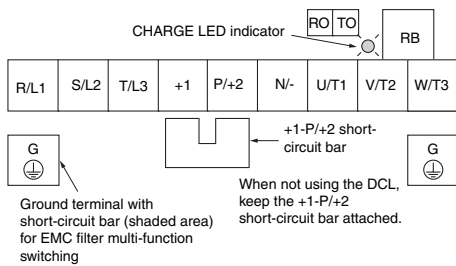

EMC filter functions switching method

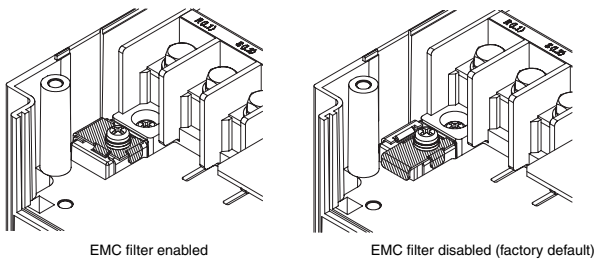

Emergency Shutoff Function

- The built-in slide switch is used to enable or disable the emergency shutoff function (Factory Default: Disabled).
- This function is intended to turn off the Inverter output (Stop switching the main element) via only the multi-function input terminal of the hardware circuit, independent of the CPU Software.

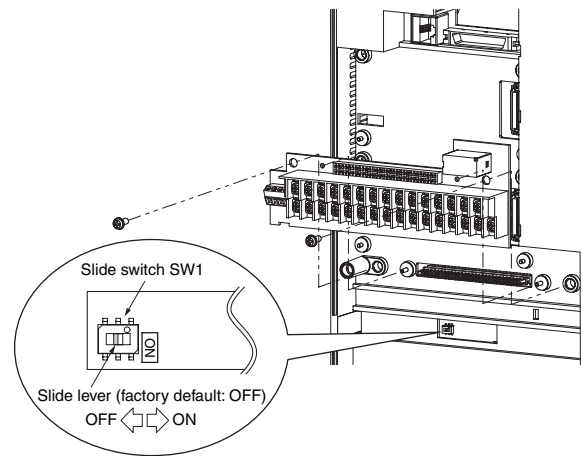

Terminal symbol	Terminal name	Description
R/L1, S/L2, T/L3	Main power supply input terminal	Connect the input power supply.
U/T1, V/T2, W/T3	Inverter output terminal	Connect to the 3-phase motor.
+1, P/+2	External DC reactor connection terminal	Remove the short-circuit bar between terminals "+1" and "P/+2", and connect the optional power factor improvement reactor.
P/+2, RB	Braking resistor connection terminals	Connect optional external braking resistors. (The RB terminal is provided for the Inverters with 22 kW or lower capacity.)
P/+2, N/-	Regenerative braking unit connection terminal	Connect optional regenerative braking units.
G	Ground terminal	Inverter case ground terminal. Connect this terminal to the ground. Class D (200 V), Class C (400 V)

Arrangement of Control Circuit Terminals

	FS	FE	AM	MP	TH	FW	S8	SC	S5	S3	S1	P4	P3	P1	MA
FC	FV	FI	AMI	P24	PSC	SC	S7	S6	S4	S2	P5	PC	P2	MC	MB

Terminal screw size M3

		Terminal symbol	Terminal name	Description	Specifications	
Analog	Power supply	FC	Frequency reference common	Common terminal for the frequency setting signals (FV, FE and FI) and the analog output terminals (AM and AMI). Do not connect this terminal to the ground.	–	
		FS	Frequency reference power supply output	+10 V DC power supply for the FV terminal.	Allowable load current: 20 mA max.	
	Frequency setting input	FV	Frequency reference input (Voltage directive)	With a 0 V to 10 V DC voltage input, the maximum frequency is set at 10 V. To set the maximum frequency at 10 V or lower, set A014.	Input impedance 10 kΩ Allowable input voltage range: –0.3 to +12 V DC	
		FE	Auxiliary frequency reference input (Voltage directive)	With a 0 to 10 V DC voltage input, the FE signal is added to the frequency reference signal of the FV or FI terminal. If the setting is changed, the frequency reference can be input even with the FE terminal independently.	Input impedance 10 kΩ Allowable input voltage 0 to ±12 V DC	
		FI	Frequency reference input (Current directive)	With a 4 to 20 mA DC current input, the maximum frequency is set at 20 mA. The FI signal is only active when the AT terminal is ON. Allocate the AT function to the multi-function input terminal.	Input impedance 100 Ω Allowable max. current: 24 mA	
	Monitor output	AM	Analog monitor (Voltage)	This terminal outputs a signal selected from the "0 V to 10 V DC Voltage Output" monitor items: Output frequency, Output current, Output torque (with/without sign), Output voltage, Input voltage, Electronic thermal relay load rate, LAD frequency, Motor temperature, Cooling fin temperature, and General-purpose output.	Allowable max. current: 2 mA	
AMI		Analog monitor (Current)	This terminal outputs a signal selected from the "4 to 20 mA DC Current Output" monitor items: Output frequency, Output current, Output torque (with/without sign), Output voltage, Input voltage, Electronic thermal relay load rate, LAD frequency, Motor temperature, Cooling fin temperature, and General-purpose output.	Allowable load impedance: 250 Ω max.		
Digital (contact)	Monitor output	MP	Multi-function digital output	This terminal outputs a signal selected from the "0 to 10 V DC Voltage Output (PWM)" monitor items: Output frequency, Output current, Output torque (with/without sign), Output voltage, Input voltage, Electronic thermal relay load rate, LAD frequency, Motor temperature, Cooling fin temperature, General-purpose output, Digital output frequency, and Digital current monitor. "Digital output frequency", and "Digital current monitor" output a digital pulse at 0/10 V DC pulse voltage and 50% duty ratio.	Allowable max. current: 1.2 mA Max. frequency: 3.6 kHz	
	Power supply	P24	Interface power supply terminal	24 V DC power supply for contact input signal. When the source logic is selected, this terminal functions as the contact input common terminal.	Allowable max. output current: 100 mA	
		SC	Input common	Common terminal for the interface power supply (P24) terminal, thermistor input (TH) terminal and digital monitor (MP) terminal. When the sink logic is selected, this terminal functions as the contact input common terminal. Do not connect this terminal to the ground.	–	
	Contact input	Function/ Selection	FW	Forward rotation command terminal	When the FW signal is ON, the motor runs forward. When it is OFF, the motor decelerates and stops.	[Contact input ON condition]
			S1	Multi-function input	Select 8 functions from among the 69 functions and allocate them to from terminals S1 to S8. Note: Only terminals S1 and S3 can be used for the emergency shutoff function. For details, refer to <i>Emergency Shutoff Function</i> on page 5.	Voltage between each input terminal and the PSC terminal: 18 V DC or more. Input impedance between each input terminal and the PSC terminal: 4.7 kΩ Allowable max. voltage: Voltage between each input terminal and the PSC terminal: 27 V DC Load current at 27 V DC power supply voltage: Approx. 5.6 mA
			S2			
			S3			
			S4			
			S5			
	S6					
S7						
S8						
PSC	Multi-function input common	The sink and source logic for contact input can be switched by connecting a short-circuit bar on the control terminal block. Short-circuiting P24 and SC → Sink logic, Short-circuiting SC and PSC → Source logic To drive contact input via an external power supply, remove the short-circuit bar and connect terminal PSC to the external interface circuit.	–			

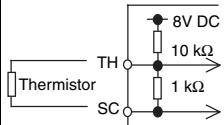
			Terminal symbol	Terminal name	Description	Specifications
Digital (contact)	Open collector output	Status/Factor	P1	Multi-function output	Select 5 functions from among 51, and allocate them to terminals P1 through P5. If an alarm code is selected in C062, terminals P1 to P3, or terminals P1 to P4 always output an alarm factor code (e.g. Inverter trip). The signal between each terminal and PC always corresponds to the sink or source logic.	Between each terminal and PC Voltage drop 4 V max. at power-on Max. allowable voltage: 27 V DC
			P2			
			P3			
			P4			
			P5			
		PC	Multi-function output common	Common terminal for multi-function output terminals P1 to P5.	Max. allowable current: 50 mA	
	Relay output	Status, alarm, etc.	MA MB	Relay output	Select the desired functions from among 43 functions, and allocate them to these terminals. SPDT output. By factory default, the relay output (MA, MB) contact selection (C036) is set at NC contact between MA-MC, and NO contact between MB-MC.	Contact max. capacity MA-MC 250 V AC, 2 A (Resistance) 0.2 A (Induction) MB-MC 250 V AC, 1 A (Resistance) 0.2 A (Induction) Contact min. capacity 100 V AC, 10 mA 5 V DC, 100 mA
MC			Relay output common			
Analog	Analog input	Sensor	TH	External thermistor input Terminal	Connect an external thermistor to this terminal, to trip the Inverter when a temperature error occurs. The SC terminal functions as the common terminal. [Recommended thermistor characteristics] Allowable rated power: 100 mW min. Impedance at temperature error: 3 kΩ Temperature error detection level is adjustable between 0 and 9999 Ω.	Allowable input voltage range 0 to 8V DC [Input circuit] 

Standard Connection Diagram

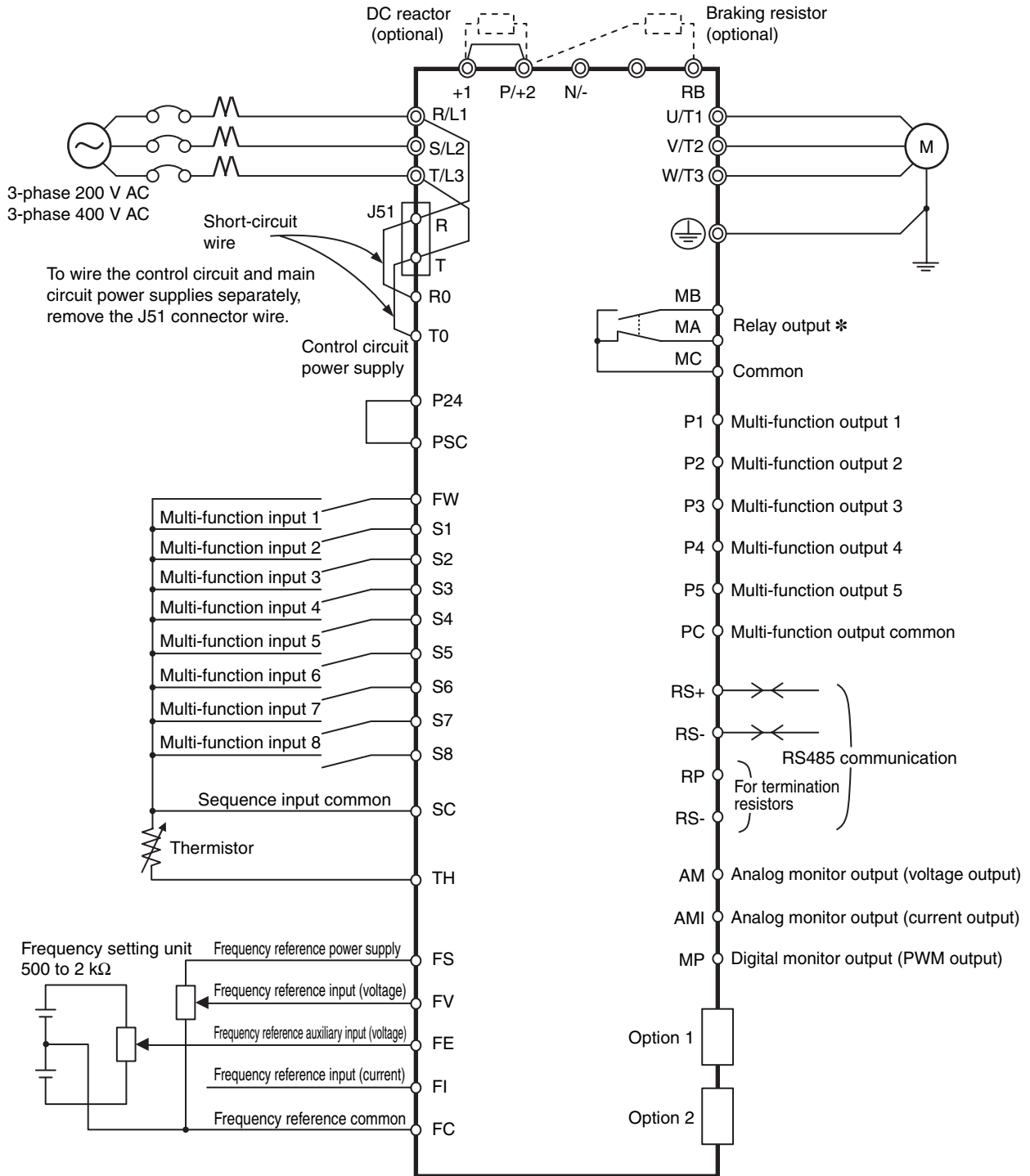

* By default, MA is set to MC contact, and MB to NO contact in the contact selection (C036).

Nomenclature and Functions

Inverter Nomenclature and Functions

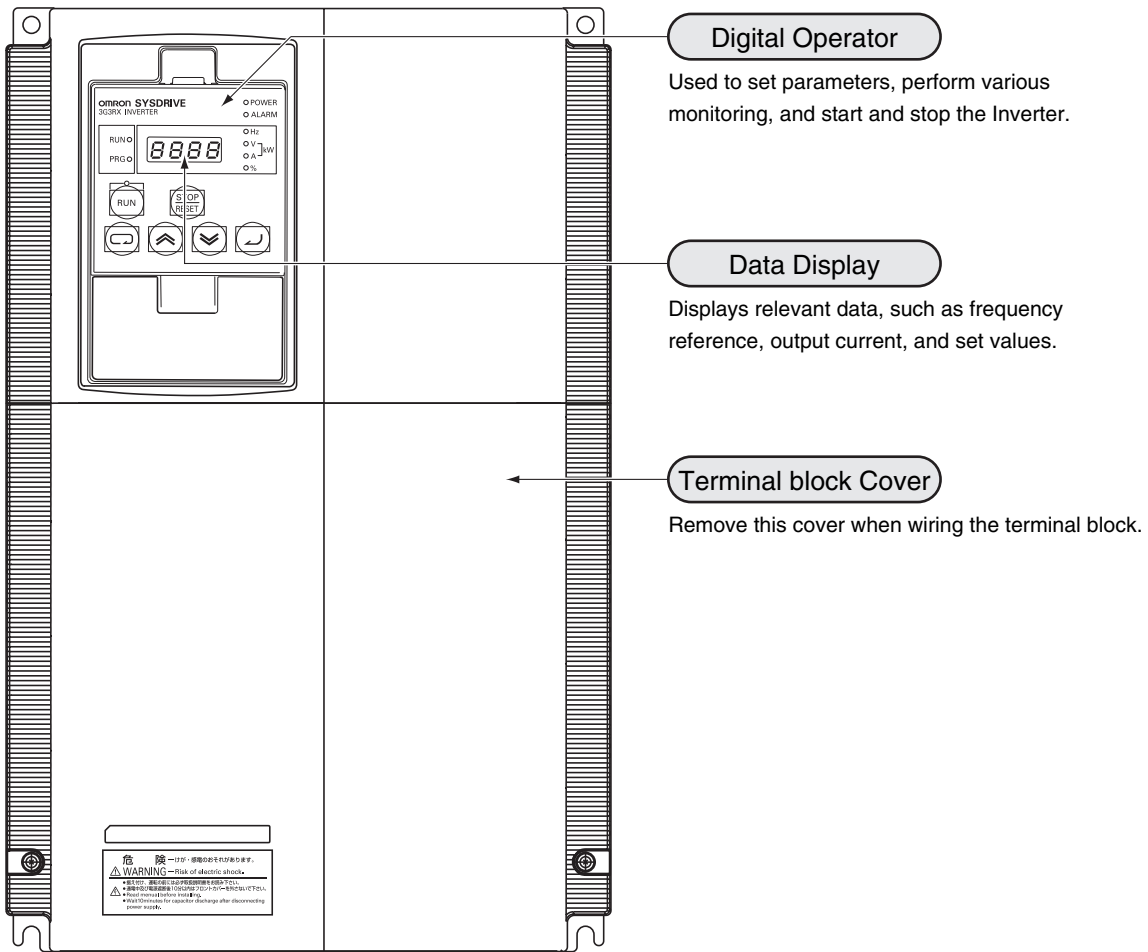

Part Names and Descriptions of the Digital Operator

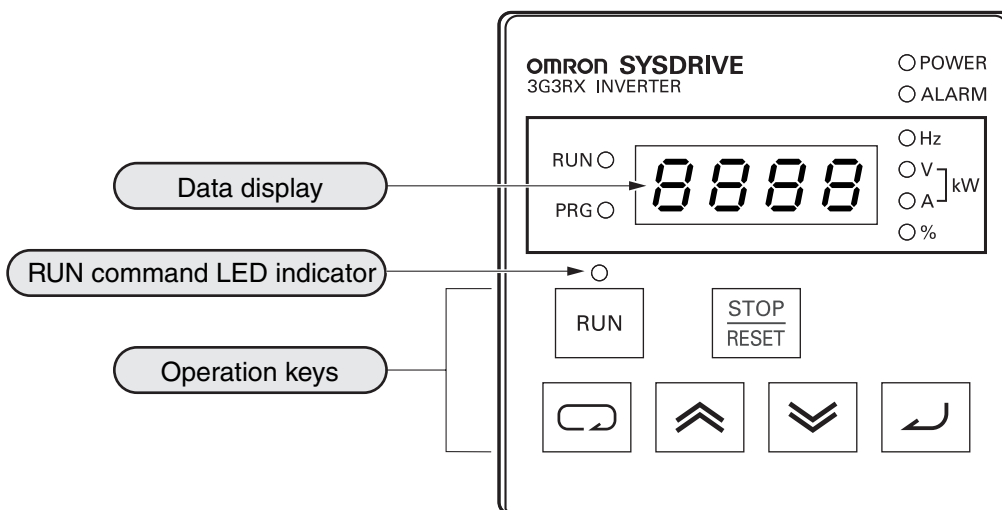

	Name	Function
<input type="radio"/> POWER	POWER LED indicator	Lit when the power is supplied to the control circuit.
<input type="radio"/> ALARM	ALARM LED indicator	Lit when an Inverter error occurs.
RUN <input type="radio"/>	RUN (during RUN) LED indicator	Lit when the Inverter is running.
PRG <input type="radio"/>	PROGRAM LED indicator	Lit when the set value of each function is indicated on the data display. Blinks during warning (when the set value is incorrect).
	Data display	Displays relevant data, such as frequency reference, output current, and set values.
<input type="radio"/> Hz <input type="radio"/> V <input type="radio"/> A } kW <input type="radio"/> %	Data display LED indicator	Lit according to the indication on the data display. Hz: Frequency V: Voltage A: Current kW: Power %: Ratio
<input type="radio"/>	RUN command LED indicator	Lit when the RUN command is set to the Digital Operator. (The RUN key on the Digital Operator is available for operation)
	RUN key	Activates the Inverter. Available only when operation via the Digital Operator is selected. (Check that the RUN command LED indicator is lit.)
	STOP/RESET key	Decelerates and stops the Inverter. Functions as a reset key if an Inverter error occurs.
	Mode key	Switches between: the monitor mode (d□□□), the basic function mode (F□□□), and the extended function mode (A□□□, b□□□, c□□□, H□□□).
	Enter key	Enters the set value. (To change the set value, be sure to press the Enter key.)
	Increment key	Changes the mode. Also, increases the set value of each function.
	Decrement key	Changes the mode. Also, decreases the set value of each function.

Dimensions

- 3G3RX-A2055**
- 3G3RX-A2075**
- 3G3RX-A2110**
- 3G3RX-A4055**
- 3G3RX-A4075**
- 3G3RX-A4110**

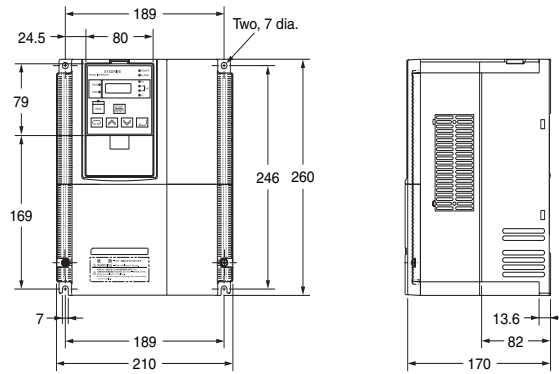

- 3G3RX-A2150**
- 3G3RX-A2185**
- 3G3RX-A2220**
- 3G3RX-A4150**
- 3G3RX-A4185**
- 3G3RX-A4220**

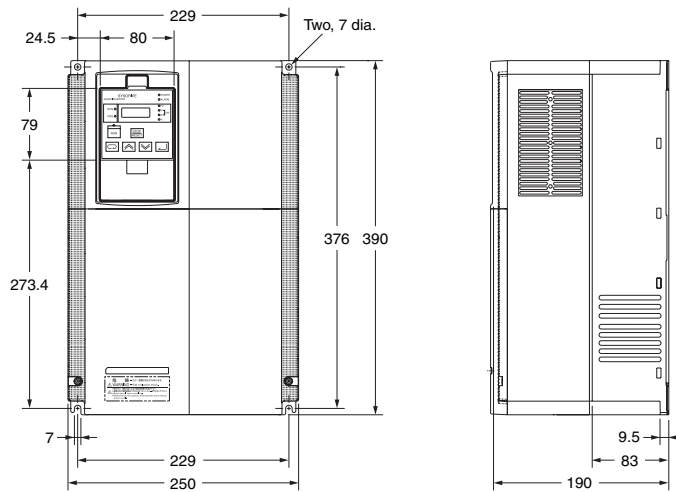

- 3G3RX-A2300**
- 3G3RX-A4300**

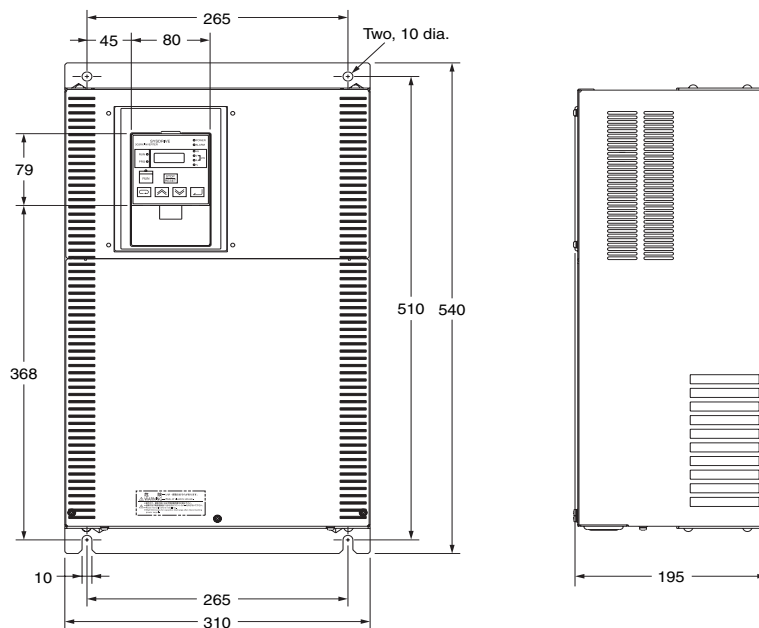

3G3RX-A2370
3G3RX-A2450
3G3RX-A4370
3G3RX-A4450
3G3RX-A4550

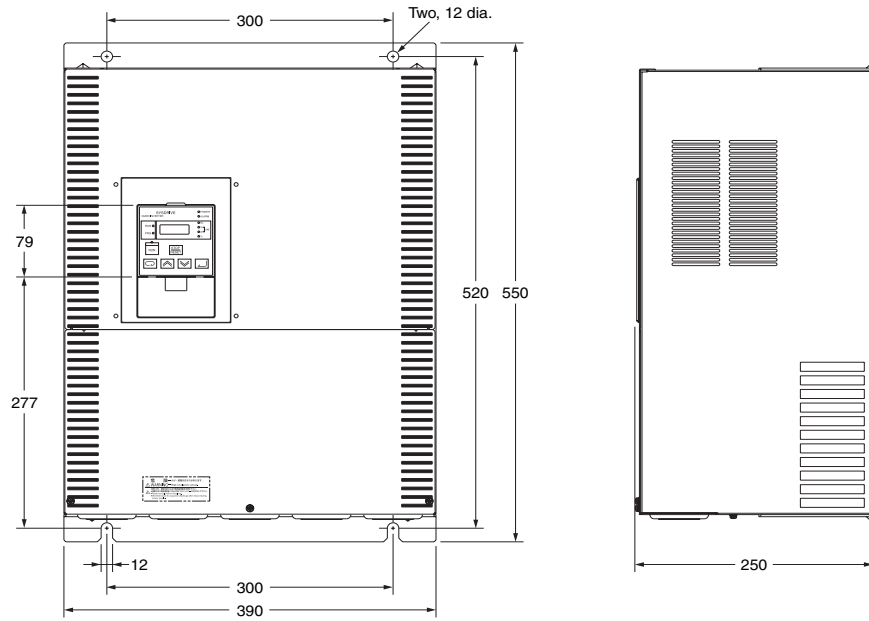

3G3RX-A2550

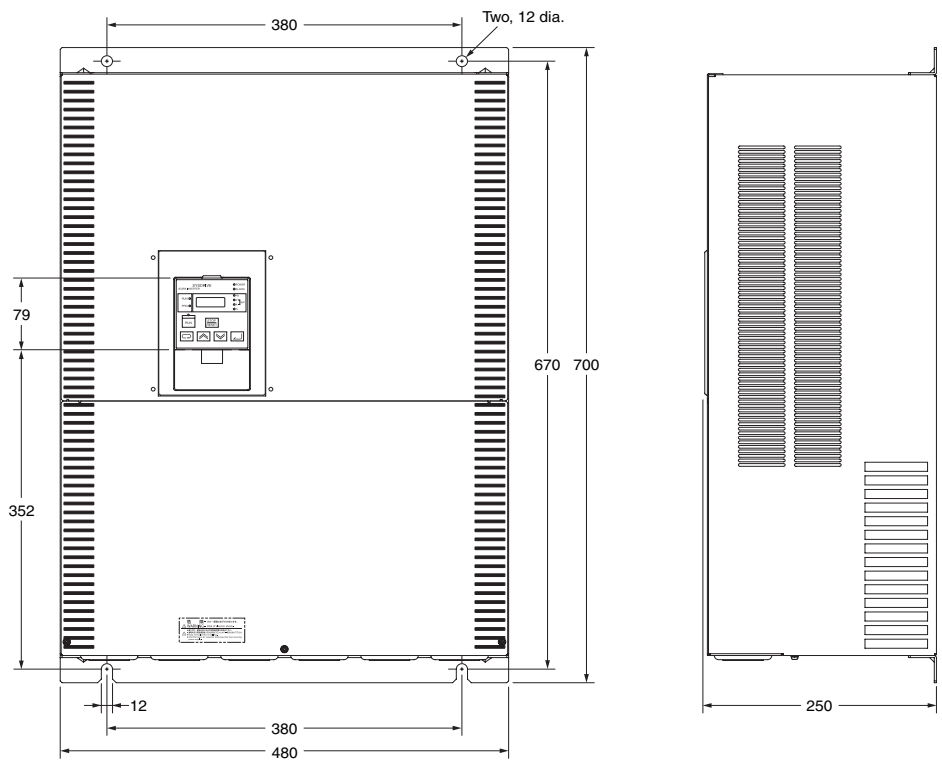

Using Digital Operator

Setting output frequency

Power ON

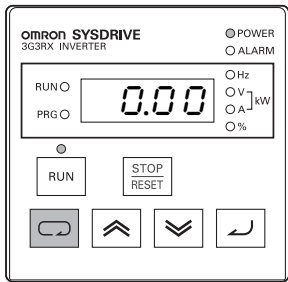

(1) 0.0 or the value previously monitored is displayed.

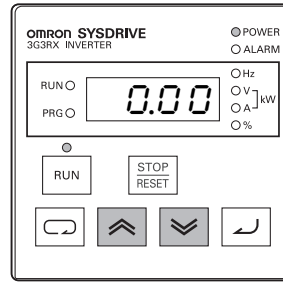

(4) Preset value is displayed.

Press key.

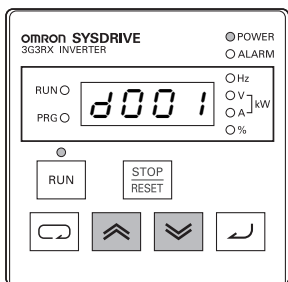

(2) Function code appears.

Press to set desired value.

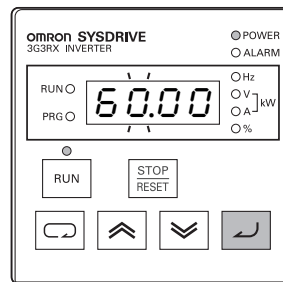

(5) Newly set value is displayed.

Press until F001 appears.

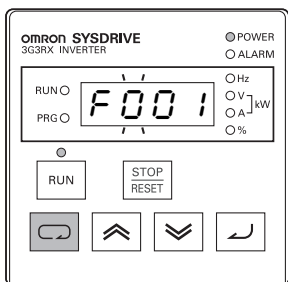

(3) F001 appears.

Press key to store the value.

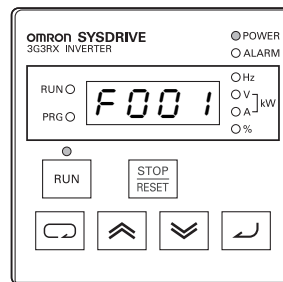

(6) Set end. (Back to F001)

Press key.

(It continues in upper right.)

Operation Example for Basic Display (factory default: "b037 = 04")

- Displays the limited basic parameters.

Monitor mode: All
 Function mode: 4 parameters
 Extended function mode: 20 parameters

- Other parameters than those mentioned above are not displayed. To display all parameters, select "Complete display 'b037 = 00'".

Parameters to be Displayed and Arrangement





No.	Display code	Item
1	d001 to d104	Monitor display
2	F001	Output frequency setting
3	F002	Acceleration time 1
4	F003	Deceleration time 1
5	F004	Digital Operator rotation direction Selection
6	A001	Frequency reference selection
7	A002	RUN command selection
8	A003	Base frequency
9	A004	Maximum frequency
10	A005	FV/FI terminal selection
11	A020	Multi-step speed reference 0
12	A021	Multi-step speed reference 1
13	A023	Multi-step speed reference 2
14	A044	V/f characteristics selection
15	A045	Output voltage gain
16	A085	RUN mode selection
17	b001	Retry selection
18	b002	Allowable momentary power interruption time
19	b008	Trip retry selection
20	b011	Trip retry wait time
21	b037	Display selection *
22	b083	Carrier frequency
23	b084	Initialization selection
24	b130	Overvoltage protection function during deceleration
25	b131	Overvoltage protection level during deceleration
26	C021	Multi-function output terminal P1 selection
27	C022	Multi-function output terminal P2 selection
28	C036	Relay output (MA, MB) contact selection

* If the target parameter is not displayed, check the setting of display selection "b037".
 To display all parameters, set "00" to "b037".

Protective and Diagnostic Functions

Error Code List

Display on Digital Operator	Name	Description
E010	Overcurrent protection	Constant speed
E020		Deceleration
E030		Acceleration
E040		Others
<p>If the motor is restrained or rapidly accelerated or decelerated, a large current will flow through the Inverter, which will result in breakage. The larger than specified current then shuts off the output and an error appears. The protection detects this overcurrent through AC CT (current detector). The protection circuit operates at approximately 220% of the Inverter rated output current and a trip occurs.</p>		
E050	Overload protection *1	Monitors the Inverter output current and shuts off the output, displaying an error if the built-in electronic thermal function detects overload against the motor. Trips depending on the electronic thermal function settings.
E060	Braking resistor overload protection	Shuts off the output and displays an error if the usage rate of regenerative braking circuit exceeds the b090 set value.
E070	Overvoltage protection	Extremely high DC voltage between P/+2 and N/- may result in failure. This function therefore shuts off the output and displays an error if the DC voltage between P/+2 and N/- exceeds the specified level because of regenerative energy from the motor or increase of the incoming voltage during operation. Trips when the DC voltage between P/+2 and N/- reaches approximately 400 V DC for 200-V class, and 800 V DC for 400-V class.
E080	EEPROM error *2 *3	Shuts off the output and displays an error if an error occurs because of external noise and abnormal temperature rise in the EEPROM built into the Inverter. Note: It may become a CPU error depending on the case.
E090	Undervoltage	Shuts off the output if the incoming voltage drops below that specified. This is because the control circuit fails to work properly, if the incoming voltage to the Inverter drops. Trips when the DC voltage between P and N reaches approximately 175 V DC for 200-V class, and 345 V DC for 400-V class.
E100	CT error	Shuts off the output if an error occurs in the CT (current detector) built into the Inverter. Trips if the CT output is approximately 0.6 V or more when the power is turned on.
E110	CPU error *3	Shuts off the output and displays an error if the internal CPU has worked erroneously or abnormally. Note: If an abnormal value is read from EEPROM, it may become a CPU error depending on the case.
E120	External trip	If an error occurs in the external equipment or devices, the Inverter receives the signal, and the output is shut off. (Available with the external trip function selected)
E130	USP error	Appears when the power is turned on with the RUN signal input into the Inverter. (Available with the USP function selected)
E140	Grounding protection *3	Protects the Inverter if a ground fault between the Inverter output unit and the motor is detected when turning on the power. (This function does not work when there is residual voltage in the motor.)
E150	Incoming overvoltage protection	Appears if the incoming voltage continues to be higher than the specification value for 100 seconds while the Inverter is stopped. Trips when the main circuit DC voltage reaches approximately 390 V DC for 200-V class, and 780 V DC for 400-V class.
E160	Momentary power interruption protection	Shuts off the output when a momentary power interruption occurs for 15 ms or more. If the shutoff time is long, it is normally recognized as a power shutoff. Note that, when restart is selected, the Inverter restarts from recovery as long as the RUN command remains.
E200	Temperature error when the rotation speed of the cooling fan decreases	Appears if a decrease of the cooling fan rotation speed has been detected when the following temperature error occurs.
E210	Temperature error	Shuts off the output if the temperature has risen in the main circuit because of the high ambient temperature.
E230	Gate array communications error	Trips when a fault is detected in communication behavior between the built-in CPU and the gate array.
E240	Input open-phase protection	Prevents Inverter damage due to input open-phase protection function when the input open-phase selection is enabled (b006=01), and trips. Trips when the open-phase time is approximately 1 s or more.
E250	Main circuit error *3	Trips when the gate array cannot confirm IGBT ON/OFF because of erroneous operation or main element breakage caused by noise interfusion.
E300	IGBT error	Shuts off the Inverter output to protect the main element when a momentary overcurrent, temperature error in the main element, or drop of the main element driving power supply occurs. (Retry operation cannot be performed after this trip.)
E350	Thermistor error	Shuts off the Inverter output when detecting the thermistor resistance value inside the motor connected to the TH terminal and resulting motor temperature rise.
E360	Brake error	When 01 is selected in b120 (brake control selection), this error appears if the brake ON/OFF cannot be recognized within the b124 set time (brake confirmation wait time) after the Inverter outputs the brake release signal.
E370	Emergency shutoff *4	Shuts off the hardware output and displays an error when the EMR terminal (S3) is turned on with SW1 on the logic board ON.
E380	Overload protection in a low speed range	If an overload is detected in the lowest speed range of 0.2 Hz max., an electronic thermal inside the Inverter works to shut off the Inverter output. (2nd electronic thermal level) (However, higher frequency could remain in the error history.)
E410	Modbus communications error	Appears when the timeout occurs because of disconnection during Modbus-RTU communication. (Trip by the C076 setting)

Display on Digital Operator	Name	Description
 	Option 1 error	Detects an error on the board mounted on option slot 1. For details, refer to the operation manual for the mounted option board.
 	Option 2 error	Detects an error on the board mounted on option slot 2. For details, refer to the operation manual for the mounted option board.

- *1. The reset command will not be accepted until approximately 10 seconds pass since the trip occurs (protection function works)
- *2. The reset command will not be accepted if the EEPROM error  occurs. Turn off the power once. If you find E08 when turning on the power again, it is possible that the memory element has been broken or the parameters have not been memorized correctly. Perform the user initialization to set the parameters again.
- *3. The reset command through the RS terminal or STOP/RESET key will not be accepted. Turn off the power.
- *4. The reset operation via the Digital Operator will not be accepted. Be sure to reset via the RS terminal.

SYSDRIVE Option

Specifications of Optional Items and Peripheral Devices

The following optional items and peripheral devices can be used with the Inverter. Select them according to the application.

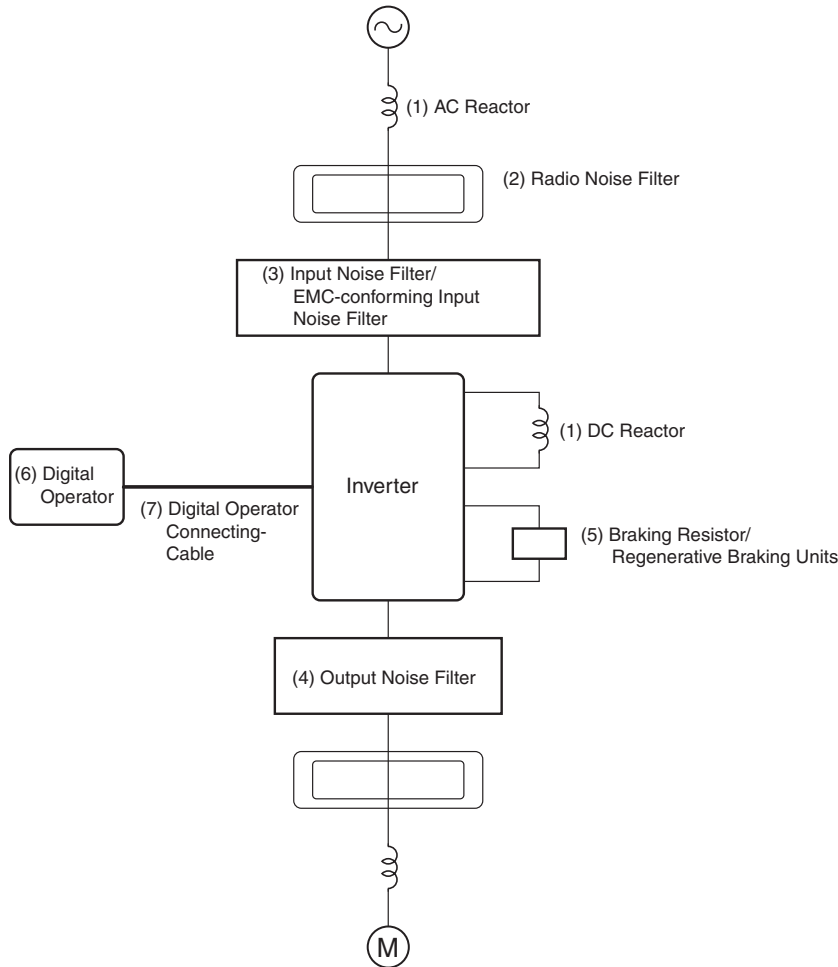

Purpose	No.	Name	Model	Description
Improve the input power factor of the Inverter	(1)	DC Reactor AC Reactor	3G3AX-DL□□□□ 3G3AX-AL□□□□	Used to improve the input power factor of the Inverter. All Inverters of 22 kW or higher contain built-in DC reactors. These are optional for Inverters of 18 kW or less. Install DC and AC reactors for applications with a large power supply capacity (600 kVA or higher).
Reduce the affects of radio and control device noise	(2)	Radio Noise Filter	3G3AX-ZCL□	Reduces noise coming into the inverter from the power supply line and to reduce noise flowing from the inverter into the power supply line. Connect as close to the Inverter as possible.
	(3)	Input Noise Filter	3G3AX-NFI□□	Reduces noise coming into the inverter from the power supply line and to reduce noise flowing from the inverter into the power supply line. Connect as close to the Inverter as possible.
		EMC-conforming Input Noise Filter	3G3AX-EFI□□	This input noise filter is for use in systems that must comply with the EC's EMC Directives. Select a filter appropriate for the Inverter model.
	(4)	Output Noise Filter	3G3AX-NFO□□	Reduces noise generated by the Inverter. Connect as close to the Inverter as possible.
Enable stopping the machine in a set time	(5)	Braking Resistor	3G3AX-RB□□□□□□	Consumes the regenerative motor energy with a resistor to reduce deceleration time (use rate: 3% ED).
		Regenerative Braking Unit	3G3AX-RBU□□	
Operates the Inverter externally	(6)	Digital Operator	3G3AX-OP□□	Remote Operator Note: MX and RX series has this operator. It's used separated the Inverter.
	(7)	Digital Operator Connecting-Cable	3G3AX-OPCN□□	Extension cable to use a Digital Operator remotely. Cable length: 1 m or 3 m

Note: Use a ground fault interrupter with a current sensitivity of 200 mA minimum and an operating time of 0.1 s minimum to prevent operating errors. The interrupter must be suitable for high-frequency operation.
 Example: NV series by Mitsubishi Electric Corporation (manufactured in or after 1998)
 EG, SG series by Fuji Electric Co., Ltd. (manufactured in or after 1984)

JX/MX/RX Series Related Options

○ : Release

Name	Model	Specifications	Applicable Series					
			JX	MX	RX			
Regenerative Braking Units	3G3AX-RBU21	3-phase 200 V	General purpose with Braking resistor			○	○	○
	3G3AX-RBU22		High Regeneration purpose with Braking resistor			○	○	○
	3G3AX-RBU23		General purpose for 30 kW *					○
	3G3AX-RBU24		General purpose for 55 kW *					○
	3G3AX-RBU41	3-phase 400 V	General purpose with Braking resistor			○	○	○
	3G3AX-RBU42		General purpose for 30 kW *					○
	3G3AX-RBU43		General purpose for 55 kW *					○
Braking Resistor	3G3AX-RBA1201	Compact type	Resistor 120 W, 180 Ω				○	○
	3G3AX-RBA1202		Resistor 120 W, 100 Ω				○	○
	3G3AX-RBA1203		Resistor 120 W, 5 Ω				○	○
	3G3AX-RBA1204		Resistor 120 W, 35 Ω				○	○
	3G3AX-RBB2001	Standard type	Resistor 200 W, 180 Ω				○	○
	3G3AX-RBB2002		Resistor 200 W, 100 Ω				○	○
	3G3AX-RBB3001		Resistor 300 W, 50 Ω				○	○
	3G3AX-RBB4001		Resistor 400 W, 35 Ω				○	○
	3G3AX-RBC4001	Medium capacity type	Resistor 400 W, 50 Ω					○
	3G3AX-RBC6001		Resistor 600 W, 35 Ω					○
3G3AX-RBC12001	Resistor 1200 W, 17 Ω					○		
DC Reactor	3G3AX-DL2002	3-phase 200 V	0.2 kW			○	○	○
	3G3AX-DL2004		0.4 kW			○	○	○
	3G3AX-DL2007		0.7 kW			○	○	○
	3G3AX-DL2015		1.5 kW			○	○	○
	3G3AX-DL2022		2.2 kW			○	○	○
	3G3AX-DL2037		3.7 kW			○	○	○
	3G3AX-DL2055		5.5 kW			○	○	○
	3G3AX-DL2075		7.5 kW			○	○	○
	3G3AX-DL2110		11 kW					○
	3G3AX-DL2150		15 kW					○
	3G3AX-DL2220		22 kW					○
	3G3AX-DL2300		30 kW					○
	3G3AX-DL2370		37 kW					○
	3G3AX-DL2450		45 kW					○
	3G3AX-DL2550		55 kW					○
	3G3AX-DL4004	3-phase 400 V	0.4 kW			○	○	○
	3G3AX-DL4007		0.7 kW			○	○	○
	3G3AX-DL4015		1.5 kW			○	○	○
	3G3AX-DL4022		2.2 kW			○	○	○
	3G3AX-DL4037		3.7 kW			○	○	○
	3G3AX-DL4055		5.5 kW			○	○	○
	3G3AX-DL4075		7.5 kW			○	○	○
	3G3AX-DL4110		11 kW					○
	3G3AX-DL4150		15 kW					○
	3G3AX-DL4220		22 kW					○
	3G3AX-DL4300		30 kW					○
	3G3AX-DL4370		37 kW					○
	3G3AX-DL4450		45 kW					○
	3G3AX-DL4550		55 kW					○
	Radio Noise Filter		3G3AX-ZCL1				○	○
3G3AX-ZCL2					○	○	○	

* The braking resistor is optionally required.

Name	Model	Specifications		Applicable Series		
				JX	MX	RX
Input Noise Filter	3G3AX-NFI21	3-phase 200 V	0.2 to 0.75 kW	○	○	○
	3G3AX-NFI22		1.5 kW	○	○	○
	3G3AX-NFI23		2.2, 3.7 kW	○	○	○
	3G3AX-NFI24		5.5 kW	○	○	○
	3G3AX-NFI25		7.5 kW	○	○	○
	3G3AX-NFI26		11 kW			○
	3G3AX-NFI27		15 kW			○
	3G3AX-NFI28		18.5 kW			○
	3G3AX-NFI29		22, 30 kW			○
	3G3AX-NFI2A		37 kW			○
	3G3AX-NFI2B	45 kW			○	
	3G3AX-NFI2C	55 kW			○	
	3G3AX-NFI41	3-phase 400 V	0.2 to 2.2 kW	○	○	○
	3G3AX-NFI42		3.7 kW	○	○	○
	3G3AX-NFI43		5.5, 7.5 kW	○	○	○
	3G3AX-NFI44		11 kW			○
	3G3AX-NFI45		15 kW			○
	3G3AX-NFI46		18.5 kW			○
	3G3AX-NFI47		22 kW			○
	3G3AX-NFI48		30 kW			○
3G3AX-NFI49	37 kW				○	
3G3AX-NFI4A	45, 55 kW				○	
Output Noise Filter	3G3AX-NFO01	1/3-phase 200 V 0.2 to 0.75 kW, 3-phase 400 V to 2.2 kW		○	○	○
	3G3AX-NFO02	1/3-phase 200 V 1.5, 2.2 kW, 3-phase 400 V 3.7 kW		○	○	○
	3G3AX-NFO03	3-phase 200 V 3.7, 5.5 kW, 3-phase 400 V 5.5 to 11 kW		○	○	○
	3G3AX-NFO04	3-phase 200 V 7.5, 11 kW, 3-phase 400 V 15 to 22 kW		○	○	○
	3G3AX-NFO05	3-phase 200 V 15 kW, 3-phase 400 V 30, 37 kW				○
	3G3AX-NFO06	3-phase 200 V 18.5, 22 kW, 3-phase 400 V 45 kW				○
	3G3AX-NFO07	3-phase 200 V 30, 37 kW, 3-phase 400 V 55, 75 kW				○
AC Reactor	3G3AX-AL2025	200 V	0.2 to 1.5 kW	○	○	○
	3G3AX-AL2055		2.2 to 3.7 kW	○	○	○
	3G3AX-AL2110		5.5 to 7.5 kW	○	○	○
	3G3AX-AL2220		11 to 15 kW			○
	3G3AX-AL2330		18.5 to 22 kW			○
	3G3AX-AL2500		30 to 37 kW			○
	3G3AX-AL2750		45 to 55 kW			○
	3G3AX-AL4025	400 V	0.4 to 1.5 kW	○	○	○
	3G3AX-AL4055		2.2 to 3.7 kW	○	○	○
	3G3AX-AL4110		5.5 to 7.5 kW	○	○	○
	3G3AX-AL4220		11 to 15 kW			○
	3G3AX-AL4330		18.5 to 22 kW			○
	3G3AX-AL4500		30 to 37 kW			○
	3G3AX-AL4750		45 to 55 kW			○
Encoder Feedback Board	3G3AX-PG01	For Position or Frequency Control				○
DI Board	3G3AX-DI01	PLC I/O Interface for setting Frequency, Acceleration/Deceleration time etc				○
Digital Operator	3G3AX-OP01			○	○	○
Digital Operator Connecting Cable	3G3AX-OPCN1	Cable Length 1 m		○	○	○
	3G3AX-OPCN3	Cable Length 3 m		○	○	○

Overview of Inverter Selection

Selecting the Motor Capacity

Select a motor before selecting the Inverter. Calculate the load inertia in the application, calculate the motor capacity and torque required to handle the load, and select an appropriate motor.

Simple Selection Method (Calculation of the Required Output)

With this method, you select the motor based on the output (W) required when the motor is rotating at a steady rate. This method does not include the involved calculations for acceleration and deceleration, so add some extra capacity to the calculated value when selecting the motor. This is a simple way to calculate the size of motor needed in equipment that operates at a steady rate for long periods, such as fans, conveyors, and mixing machines. This method is not suitable for the following kinds of applications:

- Applications requiring sudden start-ups
- Applications where the equipment starts and stops frequently
- Applications where there is a lot of inertia in the transmission system
- Applications with a very inefficient transmission system

Linear Motion: Steady Power P₀ (kW)

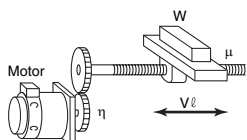

$$P_0 = \frac{m \cdot W \cdot V \ell}{6120 \cdot \eta}$$

μ : Friction coefficient
 W : Weight of moveable load (kg)
 $V \ell$: Speed of moveable load (m/min)
 η : Efficiency of reduction mechanism (transmission)

Rotational Motion: Steady Power P₀ (kW)

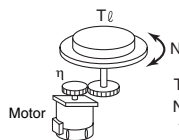

$$P_0 = \frac{T \ell \cdot N \ell}{9535 \cdot \eta}$$

$T \ell$: Load torque at load axis (N·m)
 $N \ell$: Speed of load axis (r/min)
 η : Efficiency of reduction mechanism (transmission)

Detailed Selection Method (R.M.S. Calculation Method)

With this method, you calculate the effective torque and maximum torque required in the application's operating pattern. This method provides a detailed motor selection that matches the operating pattern.

Calculating the Motor Shaft Conversion Inertia

Use the following equations to calculate the inertia of all of the parts and convert that to the motor shaft conversion inertia.

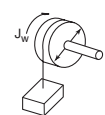

$$J_w = J_1 + J_2 = \left(\frac{M_1 \cdot D^2}{8} + \frac{M_2 \cdot D^2}{4} \right) \times 10^{-6} \text{ (kg}\cdot\text{m}^2\text{)}$$

J_w : Inertia (kg·m²)
 J_1 : Inertia of cylinder (kg·m²)
 J_2 : Inertia due to object (kg·m²)
 D : Diameter (mm)
 M_1 : Mass of cylinder (kg)
 M_2 : Mass of object (kg)

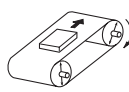

$$J_w = J_1 + J_2 + J_3 + J_4 = \left(\frac{M_1 \cdot D_1^2}{8} + \frac{M_2 \cdot D_2^2}{8} + \frac{D_1^2}{D^2} + \frac{M_3 \cdot D_1^2}{4} + \frac{M_4 \cdot D_1^2}{4} \right) \times 10^{-6} \text{ (kg}\cdot\text{m}^2\text{)}$$

J_w : Inertia (kg·m²)
 J_1 : Inertia of cylinder 1 (kg·m²)
 J_2 : Inertia of cylinder 2 (kg·m²)
 J_3 : Inertia due to object (kg·m²)
 J_4 : Inertia due to belt (kg·m²)
 D : Diameter of cylinder 1 (mm)
 D_1 : Diameter of cylinder 1 (mm)
 D_2 : Diameter of cylinder 2 (mm)
 M_1 : Mass of cylinder 1 (kg)
 M_2 : Mass of cylinder 2 (kg)
 M_3 : Mass of object (kg)
 M_4 : Mass of belt (kg)

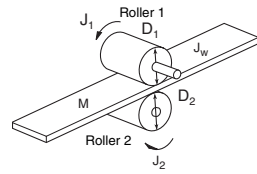

$$J_w = J_1 + \left(\frac{D_1}{D_2} \right)^2 J_2 + \frac{M \cdot D_1^2}{4} \times 10^{-6} \text{ (kg}\cdot\text{m}^2\text{)}$$

J_w : Inertia of entire system (kg·m²)
 J_1 : Inertia of roller 1 (kg·m²)
 J_2 : Inertia of roller 2 (kg·m²)
 D_1 : Diameter of roller 1 (mm)
 D_2 : Diameter of roller 2 (mm)
 M : Effective mass of workpiece (kg)

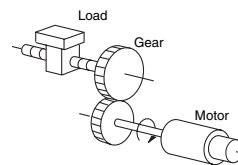

$$J_L = J_1 + G^2 (J_2 + J_w) \text{ (kg}\cdot\text{m}^2\text{)}$$

J_1 : Motor shaft conversion load inertia (kg·m²)
 J_w : Load inertia (kg·m²)
 J_2 : Motor gear inertia (kg·m²)
 J_2 : Load gear inertia (kg·m²)
 Z_1 : Number of gear teeth on motor side
 Z_2 : Number of gear teeth on load side
 Gear ratio $G = Z_1/Z_2$

Calculating the Motor Shaft Conversion Torque and Effective Torque

Calculate the total combined torque required for the motor to operate based on the acceleration torque due to the motor shaft conversion load inertia (calculated above) and the load torque due to friction force and the external force applied to the load.

Acceleration Torque

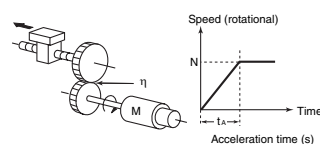

$$T_A = \frac{2\pi N}{60 t_a} \left(J_m + \frac{J_L}{\eta} \right) \text{ (N}\cdot\text{m)}$$

T_A : Acceleration Torque (N·m)
 J_m : Inertia of motor itself (kg·m²)
 J_L : Gear transmission efficiency
 N : Motor speed (r/min)

Motor Conversion Load Torque (External and Friction)

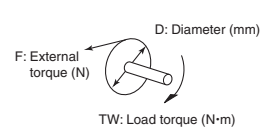

$$T_w = F \cdot \frac{D}{2} \times 10^{-3} \text{ (N}\cdot\text{m)}$$

F : External torque (N)
 D : Diameter (mm)
 T_w : Load torque (N·m)

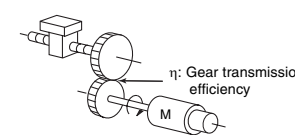

$$T_L = T_w \cdot \frac{G}{\eta} \text{ (N}\cdot\text{m)}$$

T_L : Motor shaft conversion load torque (N·m)
 T_w : Load torque (N·m)
 Z_1 : Number of gear teeth on motor side
 Z_2 : Number of gear teeth on load side
 Gear (reduction) ratio $G = Z_1/Z_2$

Selecting the Inverter Capacity

Calculating the Combined Torque and Effective Torque

Effective torque: T_{RMS} (N·m)

$$= \sqrt{\frac{\sum(T_i)^2 \cdot t_i}{\sum t_i}} = \sqrt{\frac{T_1^2 \cdot t_1 + T_2^2 \cdot t_2 + T_3^2 \cdot t_3 + T_4^2 \cdot t_4}{t_1 + t_2 + t_3 + t_4}}$$

Maximum torque: $T_{MAX} = T_1 = T_A + T_L$

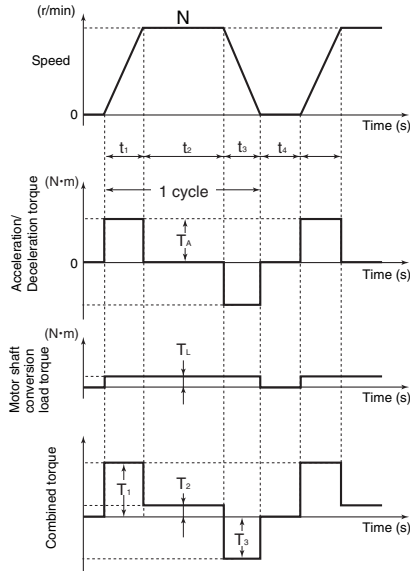

* Use the Servomotor's Motor Selection Software to calculate the motor conversion inertia, effective torque, and maximum torque shown above.

Selecting the Motor

Use the results of the calculations above and the equations below to determine the required motor capacity from the effective torque and maximum torque. Use the larger of the following motor capacities when selecting the motor.

When selecting the motor, set a motor capacity higher than the calculated capacity to provide some extra capacity.

Motor Capacity Supplied for Effective Torque:

Motor capacity (kW): $1.048 \cdot N \cdot T_{RMS} \cdot 10^{-4}$
 (N: Max. speed in r/min)

Motor Capacity Supplied for Maximum Torque:

Motor capacity (kW): $1.048 \cdot N \cdot T_{MAX} \cdot 10^{-4} / 1.5$
 (N: Max. speed in r/min)

Select an Inverter that is large enough to handle the motor selected in Selecting the Motor above. Basically, select an Inverter with a maximum motor capacity that matches the motor capacity calculated above.

After selecting the Inverter, verify that the following conditions are satisfied. If the conditions are not satisfied, select the Inverter that is one size larger and check the conditions again.

- Motor's rated current \leq Inverter's rated output current
- The application's continuous maximum torque output time \leq 1 minute

- Note: 1.** If the Inverter's overload endurance is 120% of the rated output current for one minute, check for 0.8 minute.
- 2.** When using the 0-Hz sensorless vector control, or a torque with a min. rating of 150% is frequently used under the condition that the holding torque is required with the rotation speed 0 (r/min), use an inverter with one size larger capacity than the inverter selection result.

Overview of Braking Resistor Selection

Applications Requiring Braking Resistors

In applications where excessive regenerative motor energy is produced during deceleration or descent, the main-circuit voltage in the Inverter may rise high enough to damage the Inverter. Standard Inverters, which are equipped with the overvoltage protection function, detect the overvoltage protection and stop operation, which will prevent any damage. Although the Inverter will be protected, the overvoltage protection function will generate an error and the motor will stop; this system configuration will not provide stable continuous operation.

This regenerative energy needs to be emitted to the outside of the Inverter using the braking resistor or regenerative braking unit.

About Regenerative Energy

The load connected to the motor has kinetic energy if it is rotating or potential energy if it is at a high level. The kinetic or potential energy is returned to the Inverter when the motor decelerates or lowers the load. This phenomenon is known as regeneration and the returned energy is called regenerative energy.

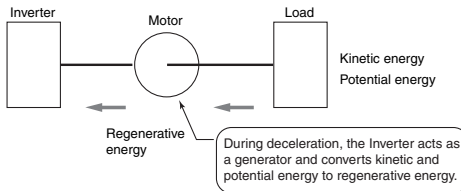

Avoiding the Use of a Braking Resistor

The following methods can be used to avoid having to connect a Braking Resistor. These methods require the deceleration time to be extended, so you must evaluate whether extending the deceleration time will cause any problems in the application.

- Enable the "stall prevention during deceleration" function; the default setting for this function is enabled. (Increase the deceleration time automatically so as not to generate the overvoltage protection.)
- Set a longer deceleration time. (This reduces the rate at which the regenerative energy is produced.)
- Select "coast to stop" as the stopping method. (Regenerative energy will not be returned to the Inverter.)

Simple Method for Braking Resistor Selection

This is a simple method for determining the braking resistance from the percentage of time that regenerative energy is produced during a normal operating pattern.

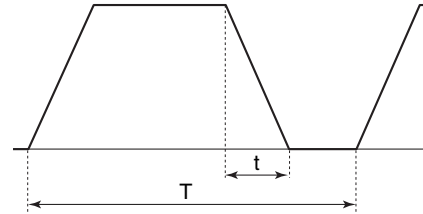

$$\text{Use rate (duty)} = t/T \times 100 (\%ED)$$

t: Deceleration time (regenerative time)

T: Time for 1 cycle of operation

For Models with a Built-in Braking Circuit (3G3MX/3G3RX Max. 18.5 kW)

Select the braking resistor based on the usage rate calculated from the operation patterns.

Refer to the braking resistor list described in the User's manual and catalog, and connect it according to your Inverter.

For Models without a Built-in Braking Circuit (3G3JX/3G3RX Min. 22 kW)

Select the regenerative braking unit and the braking resistor.

Refer to the regenerative braking unit and braking resistor lists described in the User's manual and catalog, and connect them according to your Inverter.

Detailed Method for Braking Resistor Selection

If the Braking Resistor's use rate (duty factor) exceeds 10% ED or the application requires an extremely large braking torque, use the following method to calculate the regenerative energy and select a Braking Resistor.

Calculating the Required Braking Resistance

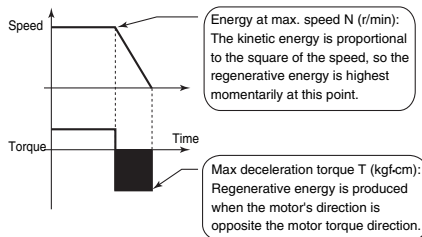

$$\text{Braking Resistor's resistance: } R \leq \frac{V^2}{1.048 \times (T - 0.2 \times T_m) \times N \times 10^{-1}}$$

- V: 385 V for a 200-V Class Inverter
400 V for a 400-V Class Inverter
- T: Maximum braking torque (kgf-cm)
- T_m: Motor's rated torque (N-cm)
- N: Maximum speed (r/min)

* Use the value for the braking torque calculated in *Calculating the Motor Shaft Conversion Torque and Effective Torque* on page 20.

Calculating the Average Regenerative Energy

Regenerative energy is produced when the motor is rotating in the opposite direction of the motor torque. Use the following equations to calculate the regenerative energy produced in each segment of the cycle.

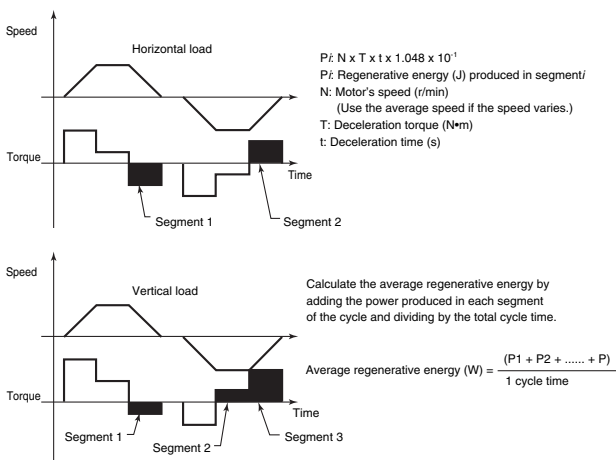

- Note: 1.** The speed is positive when the motor is rotating forward and the torque is positive when it is in the forward direction.
- 2.** Use the value for the braking torque calculated in *Calculating the Motor Shaft Conversion Torque and Effective Torque* on page 20.

Selecting the Braking Resistor

Select the appropriate Braking Resistor based on the required braking resistance and average regenerative energy that were calculated above.

- Required braking resistance \geq Braking Resistor's resistance \geq Inverter or Braking Unit's minimum resistance
- Average regenerative energy \leq Braking Resistor's allowable power

- Note: 1.** The internal braking transistor will be damaged if a resistor is connected with a resistance below the Inverter or Regenerative Braking Unit's minimum resistance. If the required resistance is less than the minimum resistance, increase the Inverter's capacity and replace the Inverter or Regenerative Braking Unit with one that has a minimum resistance less than the required resistance.
- 2.** Two or more Regenerative Braking Units can be connected in parallel. Use the following equation to determine the braking resistance when driving two or more Units.
 Braking resistance (Ω) = (required braking resistance calculated above) \times (number of Units)
- 3.** Do not select the braking resistance with the results calculated above. A rating of 150 W is not the allowed power, it is the maximum rated power in resistance units. The actual allowed power rating depends upon the resistor.